

General Specifications

Models FA1A, FA1V
Distributor

JUXTA

GS 77J08A01-01E

General

The FA1A / FA1V is a compact, front terminal connection type distributor that is used in combination with a two-wire transmitter to convert the transmitter's 4 to 20 mA DC signals into isolated DC current or DC voltage signals.

Model and Suffix Codes

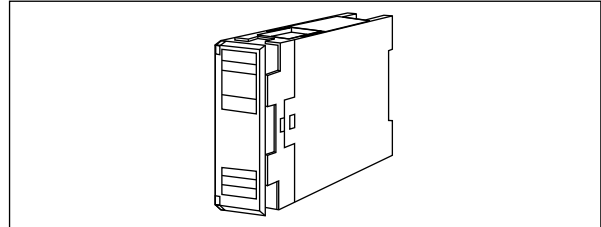
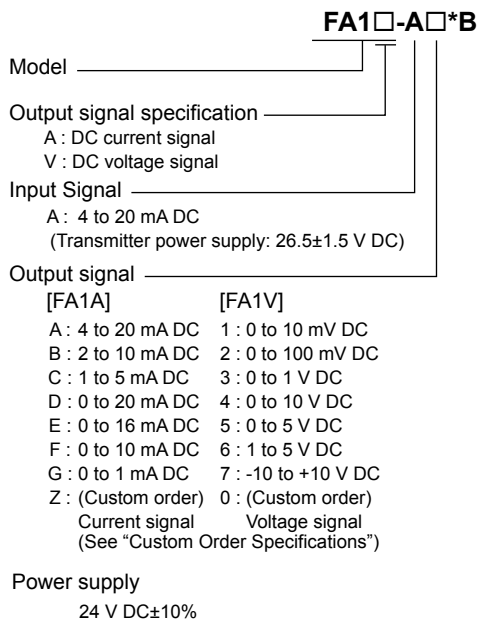

Allowable load resistance:

DC current output	Allowable load resistance	DC voltage output	Allowable load resistance
4 to 20 mA	750 Ω or less	0 to 10 mV	250 kΩ or more
2 to 10 mA	1500 Ω or less	0 to 100 mV	250 kΩ or more
1 to 5 mA	3000 Ω or less	0 to 1 V	2 kΩ or more
0 to 20 mA	750 Ω or less	0 to 10 V	10 kΩ or more
0 to 16 mA	900 Ω or less	0 to 5 V	2 kΩ or more
0 to 10 mA	1500 Ω or less	1 to 5 V	2 kΩ or more
0 to 1 mA	15 kΩ or less	-10 to +10 V	10 kΩ or more

Standard Performance

Accuracy rating: ±0.1% of span

Accuracy is not guaranteed for output level less than 0.5% of the span of a 0 to X mA output range type.

Response speed: 150 ms, 63% response (10 to 90%)

Insulation resistance: 100 MΩ or more at 500 V DC

between input and output, output and power supply, and input and power supply.

Withstand voltage: 1500 V AC/min. between input and (output and power supply).

500 V AC/min. between output and power supply.

Environmental Conditions

Operating temperature range: 0 to 50°C

Operating humidity range: 5 to 90% RH (no condensation)

Power supply voltage: 24 V DC±10% (percentage ripple is 5%p-p or less)

Effect of power supply voltage fluctuations: ±0.1% of span or less for the fluctuation within the operating range of power supply voltage specification.

Effect of ambient temperature change: ±0.2% of span or less for a temperature change of 10°C.

Current consumption:

24 V DC 110 mA (FA1A), 75 mA (FA1V)

Mounting and Dimensions

Material: ABS resin (Case body)

Mounting method: Rack, Wall or DIN rail mounting

Connection method: M4 screw terminals

External dimensions: 72 × 24 × 127 mm (H × W × D)

Weight: Approx. 130 g

Ordering Information

Specify the following when ordering.

- Model and suffix codes :e.g. FA1A-AA*B

Input/Output Specifications

Input signal: 4 to 20 mA DC signal from two-wire transmitter

Input resistance: 250 Ω

Maximum allowable input: 40 mA DC or less

Transmitter power supply: 26.5 ±1.5 V DC (provided with a current limiter to keep the current between 25 and 35 mA)

Allowable conductor resistance (RL):

Up to [(20 – transmitter's minimum operating voltage) V/0.02 A] Ω

Output signal: DC current or DC voltage signal

Zero adjustment: -1 to +1%

Span adjustment: 95 to 105%

Standard Accessories

Tag number label: 1
 Mounting block: 2
 Mounting screw: M4 screw x 2

Terminal Assignments

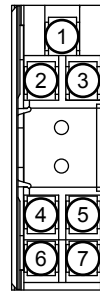

1	Input	(PS+)
2	Input	(-)(CHECK+)
3	Input	(CHECK-)
4	Output	(+)
5	Output	(-)
6	Supply	(+)
7	Supply	(-)

Custom Order Specifications

	Current Signal	Voltage Signal
Output range (DC)	0 to 24 mA	-10 to +10 V
Span (DC)	1 to 24 mA	10 mV to 20 V
Zero elevation	0 to 200%	-100 to +200%

Block Diagram

Combination with two-wire transmitter using external power supply

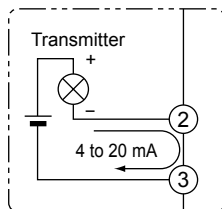

When using as an isolator

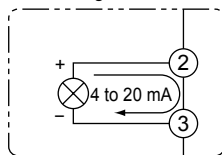

Combination with two-wire transmitter using internal power supply

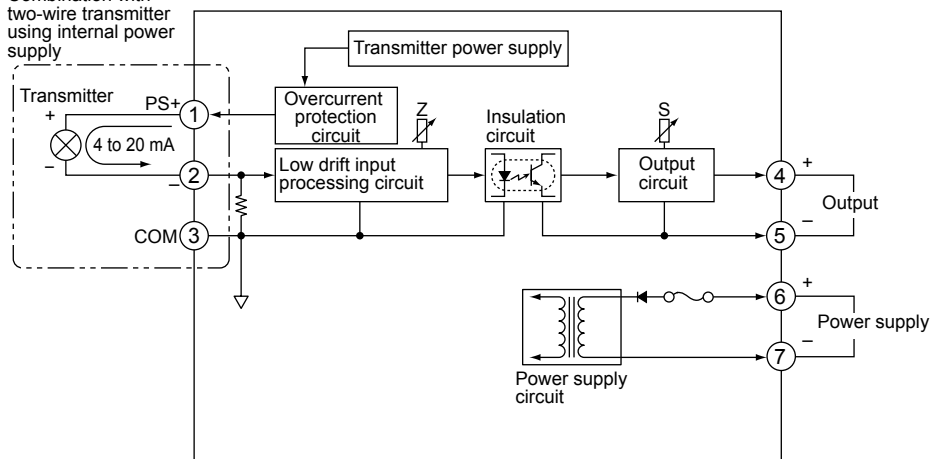

External Dimensions

